

NS 35/15 PERF 2000MM

Order No.: 1201730



<http://eshop.phoenixcontact.de/phoenix/treeViewClick.do?UID=1201730>

DIN rail, material: Steel, perforated, height 15 mm, width 35 mm,
length: 2 m

Commercial data

EAN	4017918017460
Pack	1 Meter
Customs tariff	72166190
Weight/Piece	0.629 KG
Catalog page information	Page 506 (CL-2007)

Product notes

WEEE/RoHS-compliant since:
01/10/2006



<http://www.download.phoenixcontact.com>
Please note that the data given here has been taken from the online catalog. For comprehensive information and data, please refer to the user documentation. The General Terms and Conditions of Use apply to Internet downloads.

Technical data

General data

Height	15 mm
Length	2000 mm
Width	35 mm
Material	Steel
Color	silver

Drawings

Dimensioned drawing

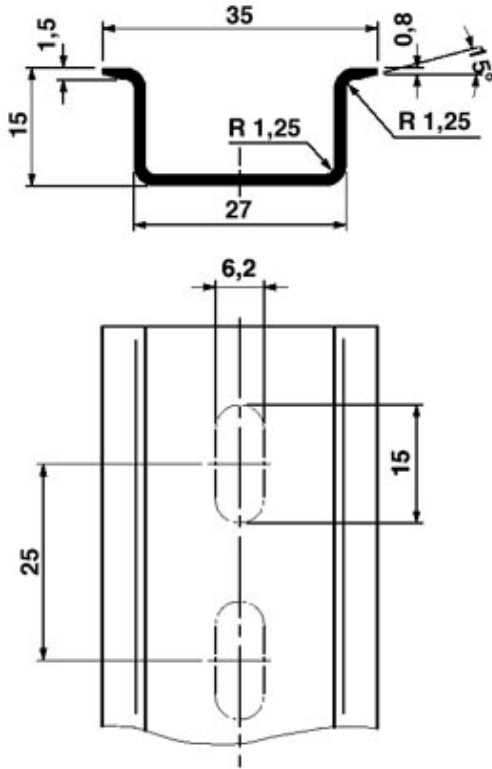

Address

PHOENIX CONTACT Inc., USA
586 Fulling Mill Road
Middletown, PA 17057, USA
Phone (800) 888-7388
Fax (717) 944-1625
<http://www.phoenixcon.com>



© 2008 Phoenix Contact
Technical modifications reserved;